

AF  
series

# AF SERIES

High Performance Vertical Machining Center

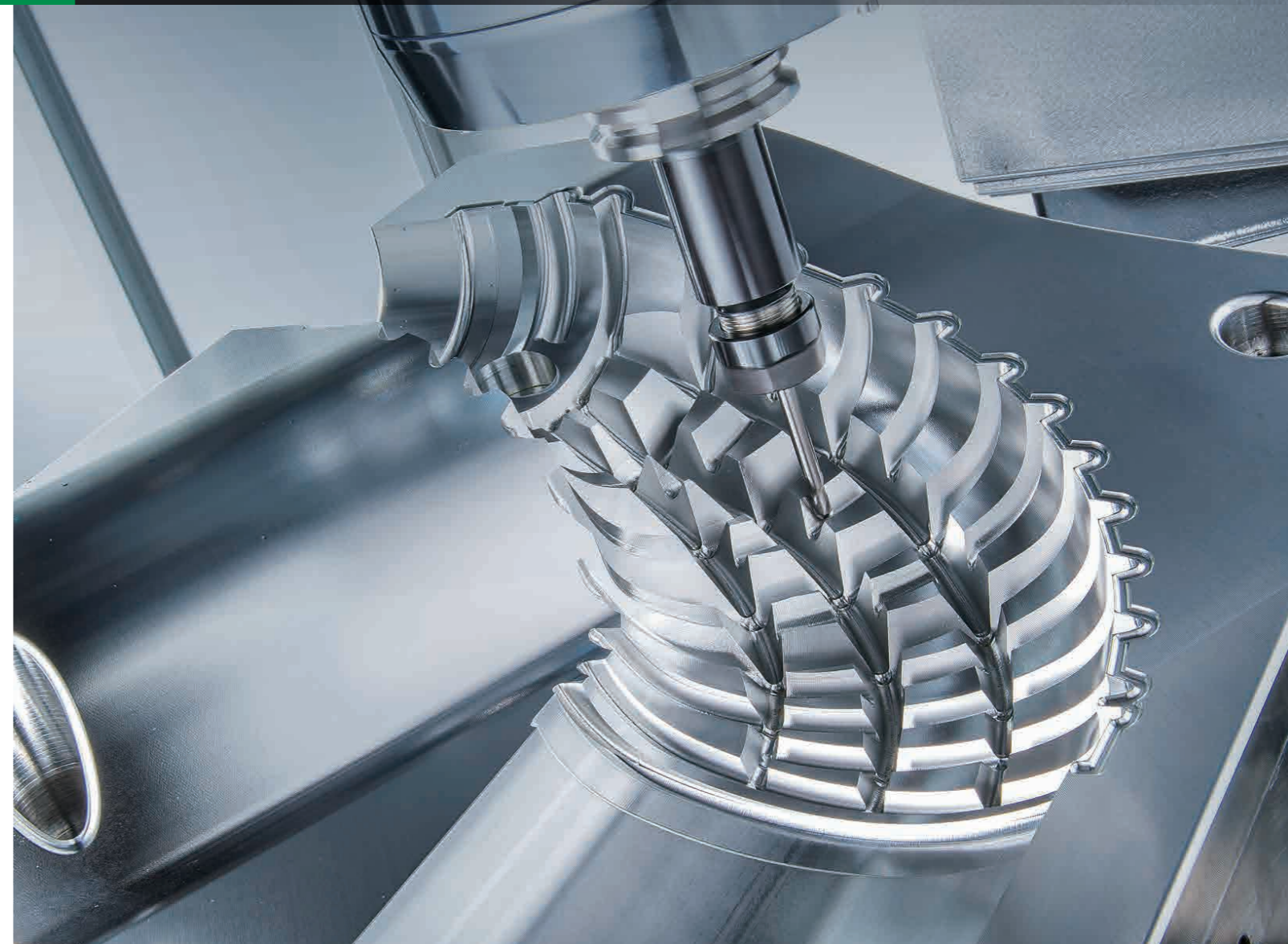

## AWEA MECHANTRONIC CO.,LTD.

### HEADQUARTERS

629, Suezhetou Section, Kwanpu Rd., Wenshan Li,  
Hsinpu, Hsinchu 305, Taiwan  
TEL : +886-3-588-5191  
FAX : +886-3-588-5194  
Website : [www.awea.com](http://www.awea.com)

### CENTRAL TAIWAN SCIENCE PARK BRANCH

15, Keyuan 2<sup>nd</sup> Rd., Central Taiwan Science Park,  
Taichung 407, Taiwan  
TEL : +886-4-2462-9698  
FAX : +886-4-2462-8002  
E-mail : [sales@awea.com](mailto:sales@awea.com)





## HIGH PERFORMANCE VERTICAL MACHINING CENTER

Introducing AWEA with mature manufacturing abilities and advanced technology skills, the AF series. They are based on high rigidity structure and three axes high precision linear guide way design with fast arm type ATC and chip conveying system. It is to provide you with fast, strong, stable machining performance. AF series are broadly used in high precision machine parts manufacturers, which can easily meet your demands of today and tomorrow.



**AF-1800**  
( X : 1,800 / Y : 800 / Z : 800 )



**AF-1060**  
( X : 1,060 / Y : 600 / Z : 600 )



**AF-860**  
( X : 860 / Y : 600 / Z : 600 )

( Unit : mm )

**AF** Series 610 / 650 / 760 / 860 / 1000  
1060 / 1250 / 1460 / 1400 / 1600 / 1800

## High Performance Vertical Machining Center

Based on AWEA's innovative technology, the AF series is specialized on high precision parts and mold machining industry. It can fully present high precision and high efficiency machining ability with very reasonable cost.

- The modular spindle design provides cutting flexibility for various machining needs.

### SOLUTION FOR PRECISION PARTS

Spindle	Taper	Speed Range
Belt-drive Spindle	BT40	8,000 ~ 10,000 rpm

### SOLUTION FOR PRECISION MOLD

Spindle	Taper	Speed Range
Direct-drive Spindle	BT40 / BT50	8,000 ~ 15,000 rpm

### SOLUTION FOR HEAVY CUTTING\*1

Spindle	Taper	Speed Range
Gear Spindle	BT40 / BT50	8,000 / 6,000 rpm

\*1 Please contact with your sales representative for applicable models.



**AF** Series 610 / 650 / 760 / 860 / 1000  
1060 / 1250 / 1460 / 1400 / 1600 / 1800

## High Performance Vertical Machining Center

Combining strong machining capability and superior quality, the AF series fulfills various machining requirements along with stable accuracy and long-lasting durability.

- X-axis travel 610 mm ~ 1,800 mm, Y / Z axes travel 450 mm ~ 800 mm.  
The complete product series can fulfill major working needs.
- High precision linear guide way design is used on three axes to provide the optimum control and efficient movement. Also, base on the actual machining application, customers can either select roller type or ball type linear guide way.
- Highly efficiency 24T arm type magazine design provides fast and reliable tool change system.
- Rotary operation panel and large width of protection door provide convenient operation display and spacious space for loading and unloading parts.
- Independent coolant tank system provide ease of maintenance.
- High pressure coolant pump efficiently increase cooling capability.



# AF

## Series

610 / 650 / 760 / 860 / 1000  
1060 / 1250 / 1460 / 1400 / 1600 / 1800

## High Performance Vertical Machining Center



### High Rigidity Structure

- The Finite Element Analysis ( FEA ) provides optimal machine design and light-weight structure advantage while ensuring high rigidity of machine.
- The MEEHANITE casting bed and Y-shaped column design provide solid support to ensure ultimate dynamic accuracy.
- $\Delta$  ( Delta ) Wide span column structure provides optimal machining rigidity. The headstock retains stability and accuracy even under high speed traveling.
- The contact surface of the column and bed are all hand scraped to ensure precision assembly, strong structure and loading balance.

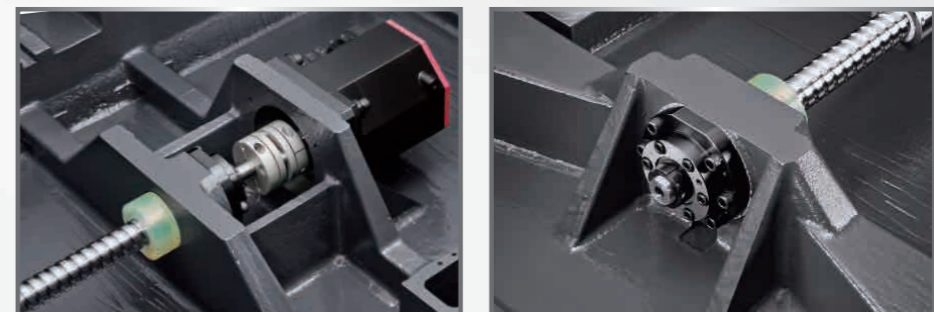
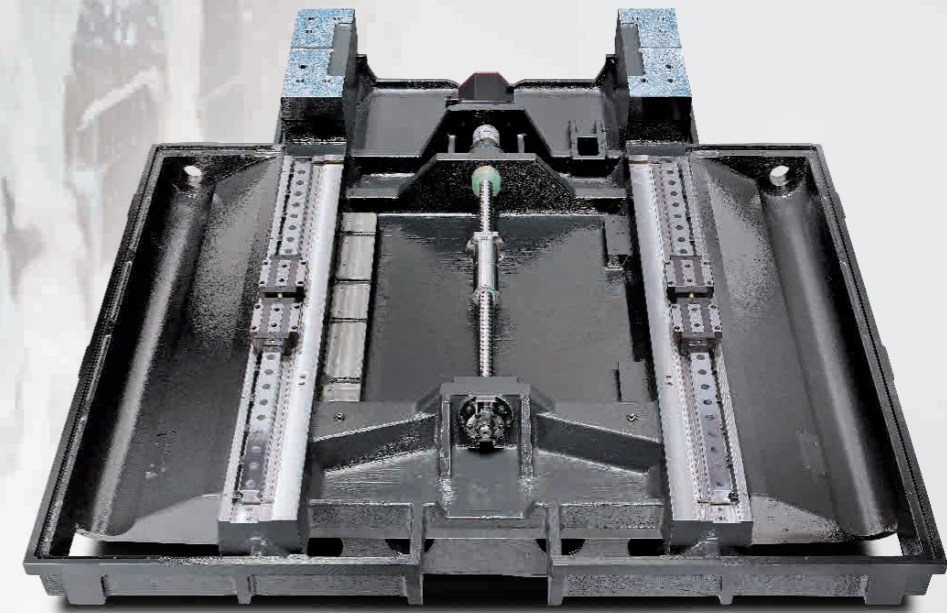
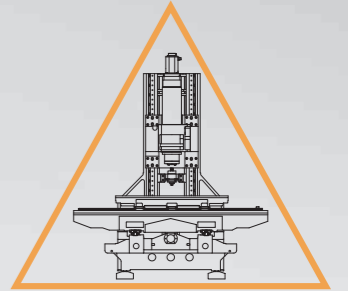

- One-piece ball screw driving motor support and bearing support enable cutting force to spread evenly into casting body, so it efficiently enhances axial system of entire rigidity and prevents deformation of ball screw.
- Contact surfaces between nut and support are hand scraped to ensure perfect contact.

# AF

## Series

610 / 650 / 760 / 860 / 1000

1060 / 1250 / 1460 / 1400 / 1600 / 1800

## High Performance Vertical Machining Center

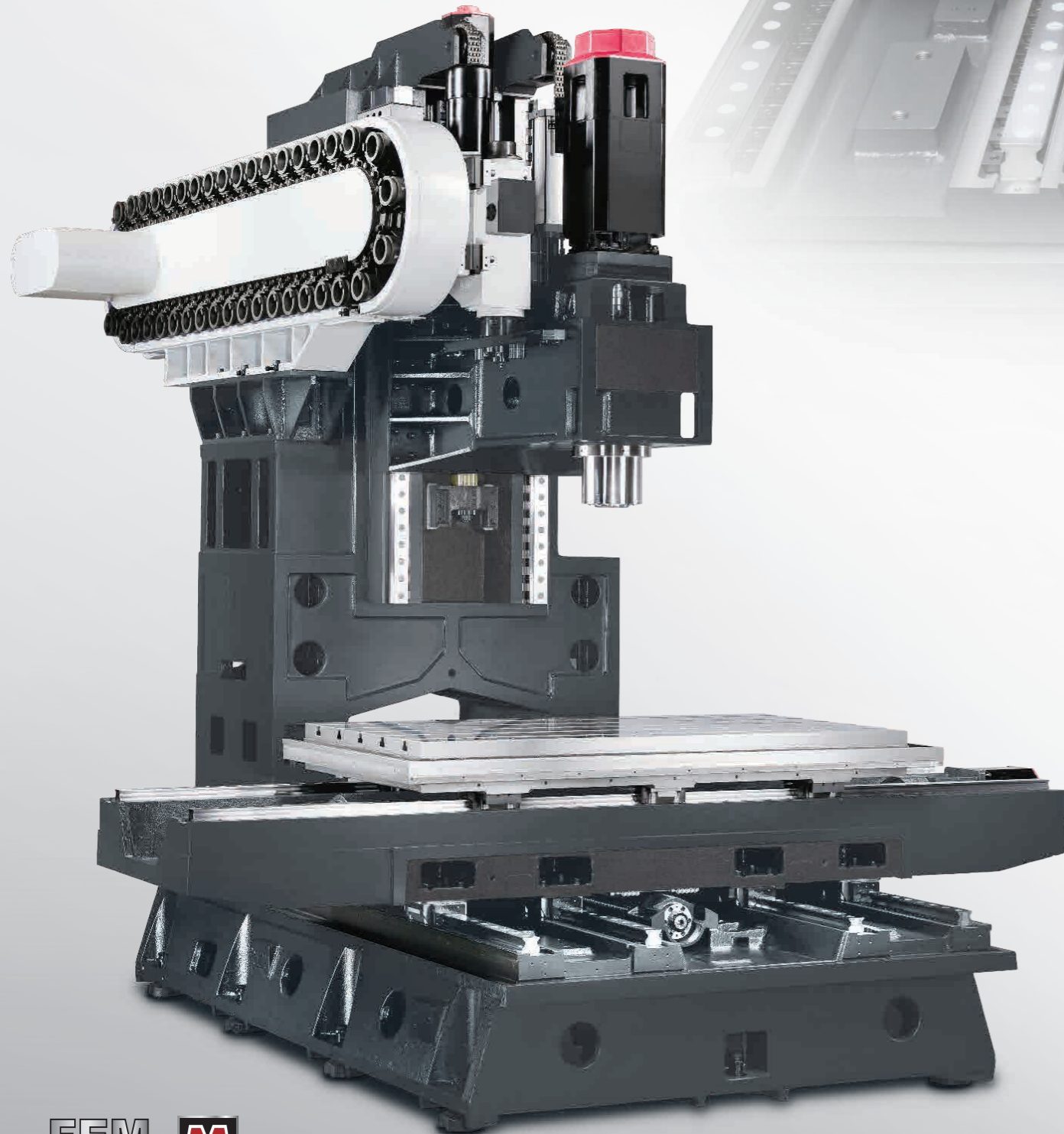

( Casting structure of AF-1600 w/ direct-drive spindle model shown )

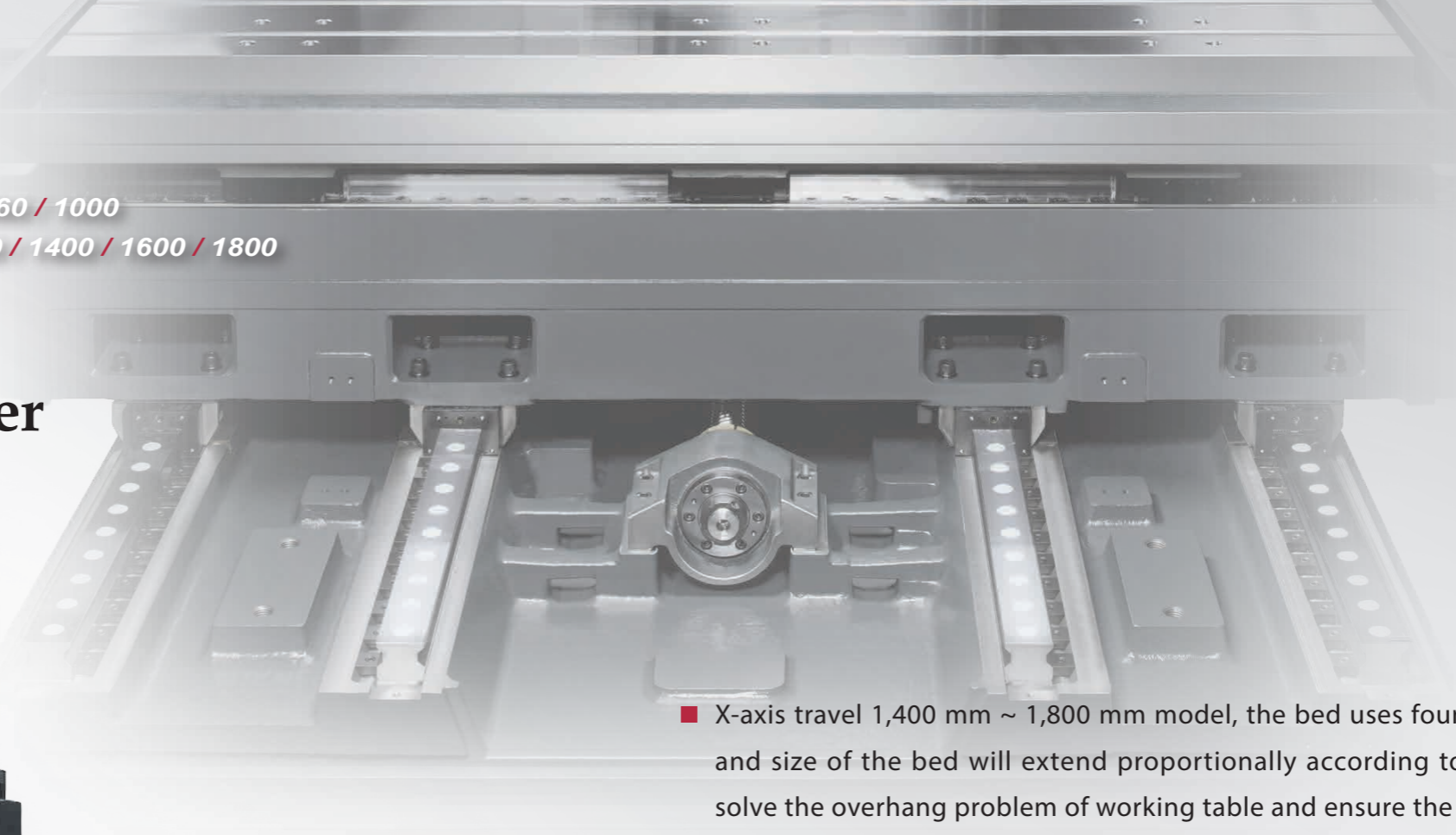

■ X-axis travel 1,400 mm ~ 1,800 mm model, the bed uses four linear guide ways design, and size of the bed will extend proportionally according to travel length in order to solve the overhang problem of working table and ensure the optimum support rigidity.

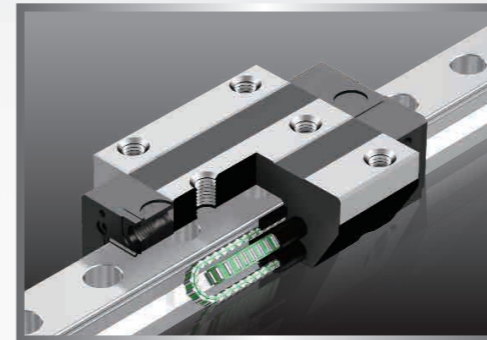

■ High rigidity roller type linear guide way which combines heavy cutting ability from ground box way and fast movement with low abrasion ability from linear guide way completely improves rigidity and control of machine.



■ High precision dual-nuts ball screw provides excellent heavy cutting rigidity while ensuring machining accuracy and extend durability of ball screw.

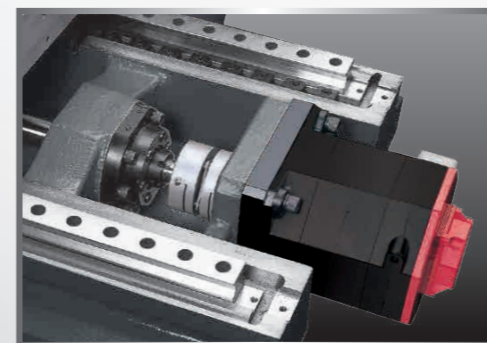

■ Three axial system are adopted with FANUC  $\alpha i$  absolute AC servo motor direct drive to provide great thrust and fast acceleration / deceleration movement. Plus, it efficiently decreases motor load and reduces generation of heat while maintaining the ultimate performance and accuracy.

# High Performance Spindle System

## High Efficiency Belt-drive Spindle

- The high efficiency belt-drive spindle provides 8,000 rpm or 10,000 rpm spindle speed which depends on machining requirements.
- The spindle is equipped with FANUC  $\alpha$  8i motor which provides maximum output of 11 kW.
- All series are standard with spindle oil cooler system to prevent thermal expansion effects and thermal deformation.
- The contact surfaces between headstock and spindle are all precisely hand scraped to ensure optimal performance and precision.

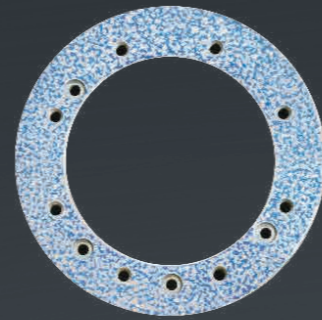

## High Torque Gear Spindle

- 2-speed super heavy-duty gear box.\*1
- Floating type hydraulic tool release device eliminates pressure on the spindle bearing when releasing a tool.
- 8,000 rpm high torque spindle ( BT40 ) is equipped with powerful 11 kW motor delivers maximum torque output of 280 N-m at 375 rpm to meet various working conditions.
- 6,000 rpm high torque spindle ( BT50 ) is equipped with powerful 15 kW motor delivers maximum torque output of 382 N-m at 375 rpm.



\*1 Gear spindle are all equipped with box way Z-axis.

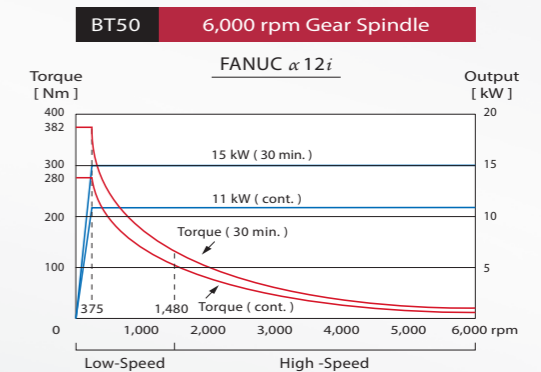
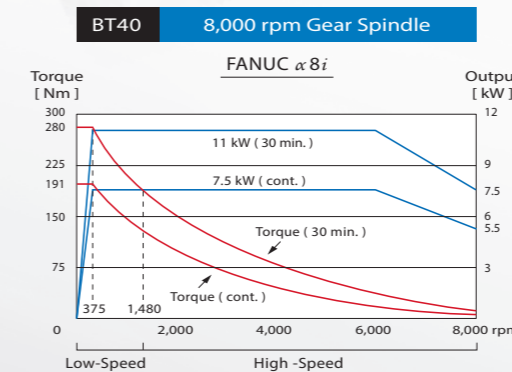
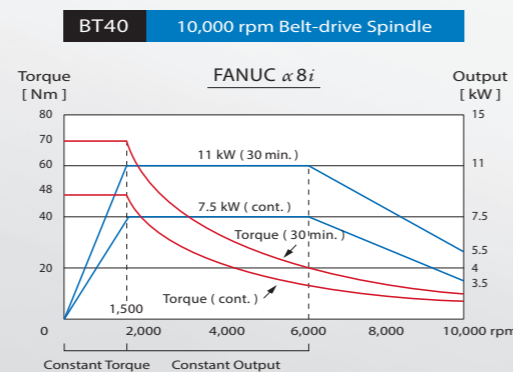
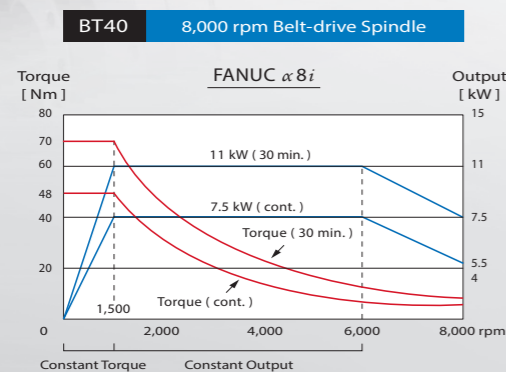

▶ FANUC  $\alpha$  12i/  $\alpha$  15i motor are available.

▶ FANUC  $\alpha$  15i/  $\alpha$  18i motor are available.

# High Performance Spindle System

## High Speed, High Power Direct-drive Spindle

- Direct-drive spindle efficiently separates the heat generated from the motor, which reduces deformation, therefore increasing machining accuracy.
- Floating type hydraulic tool release device eliminates pressure on the spindle bearing when releasing a tool.
- Several options of spindle heads and speed are available to fulfill various high speed machining requirements.

- Direct-drive spindle provides ability of precise contour machining to fulfill requirements of mold industry and high accuracy requirement components.

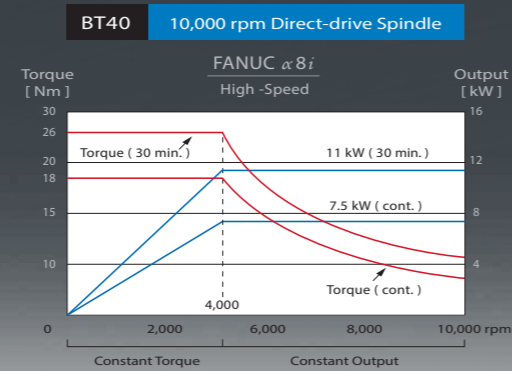
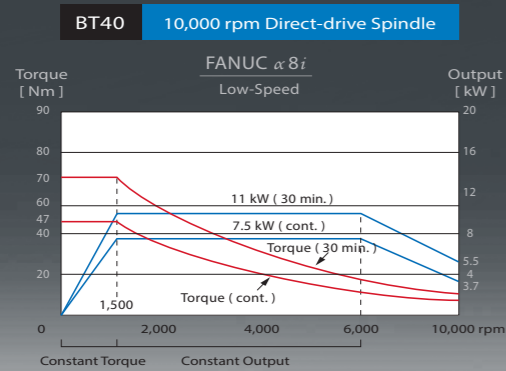
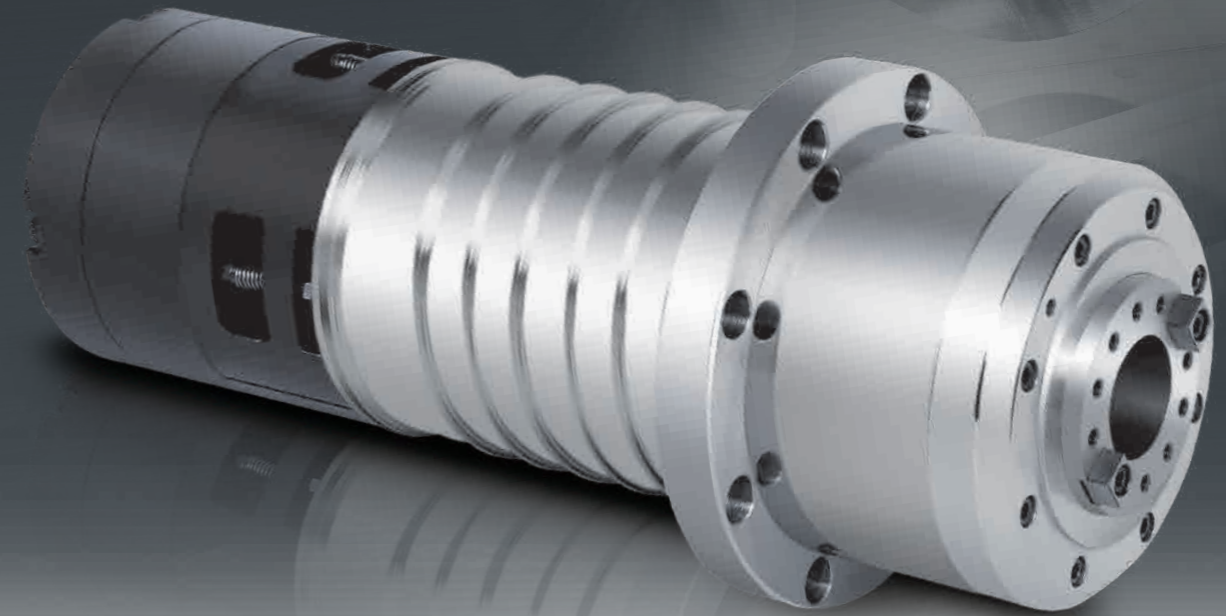

▶ FANUC  $\alpha 12i$  motor is also available.

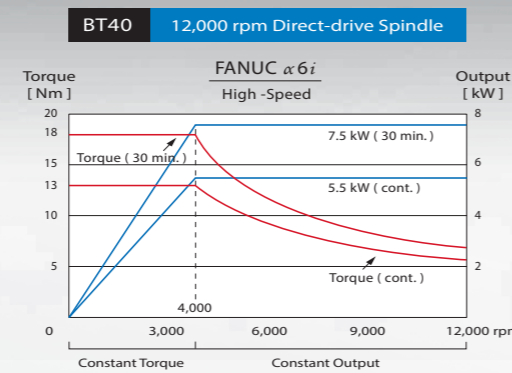
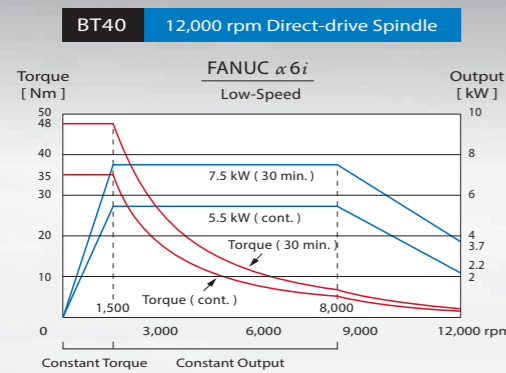

▶ FANUC  $\alpha 12i$  /  $\alpha 15i$  motor are available.

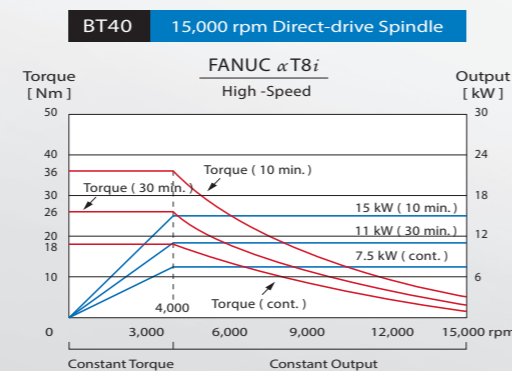
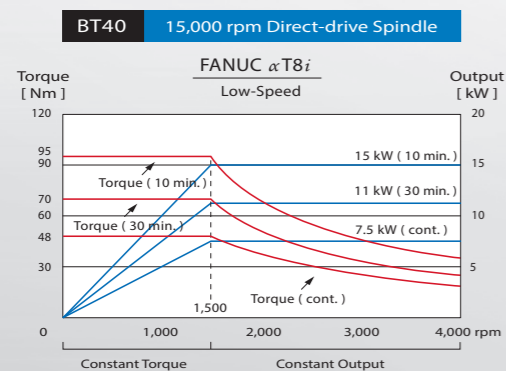

▶ FANUC  $\alpha 15i$  motor is also available.

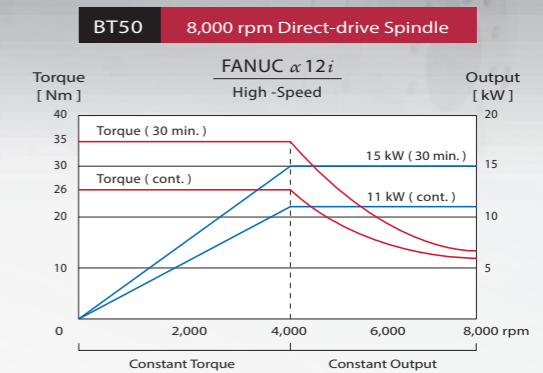
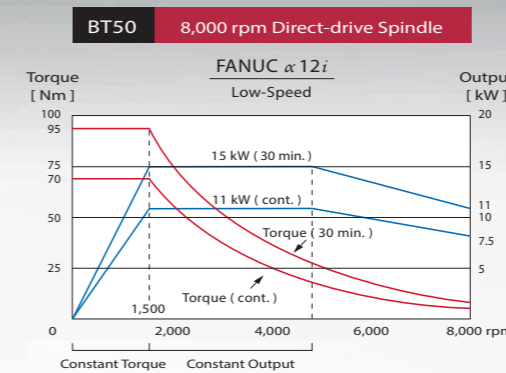

▶ FANUC  $\alpha 15i$  motor is also available.

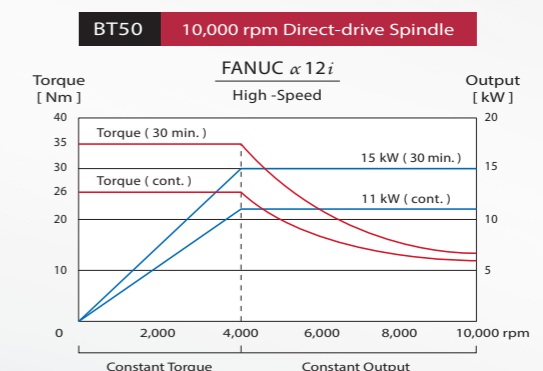
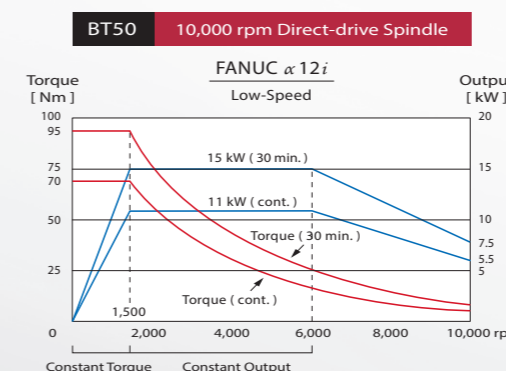

▶ FANUC  $\alpha 15i$  motor is also available.



## High Speed ATC System

- All series are standard with 24T arm type ATC system which can easily fulfill various types of processing needs.
- Standard shortcut tool change function can shorten tool change time and increase working efficiency.
- The tool magazine is supported by the column base, which increases stability and lowers the tool change vibration, while ensuring its precision ( AF-1250 ~ AF-1800 ).

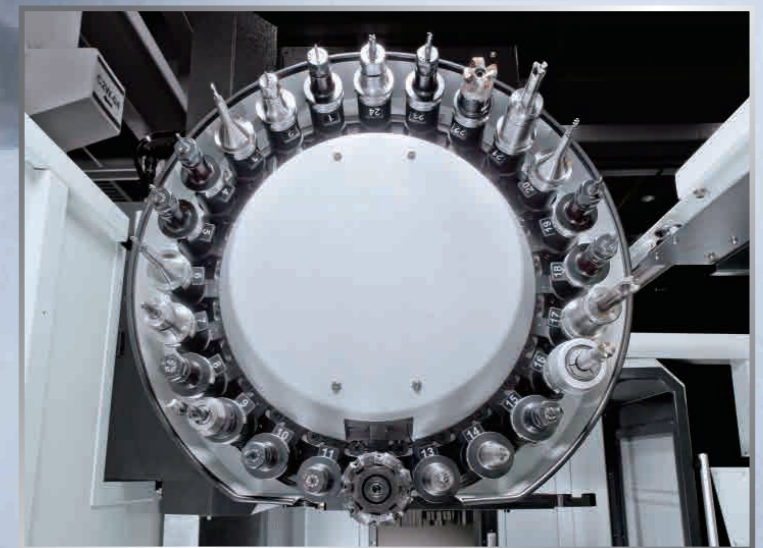
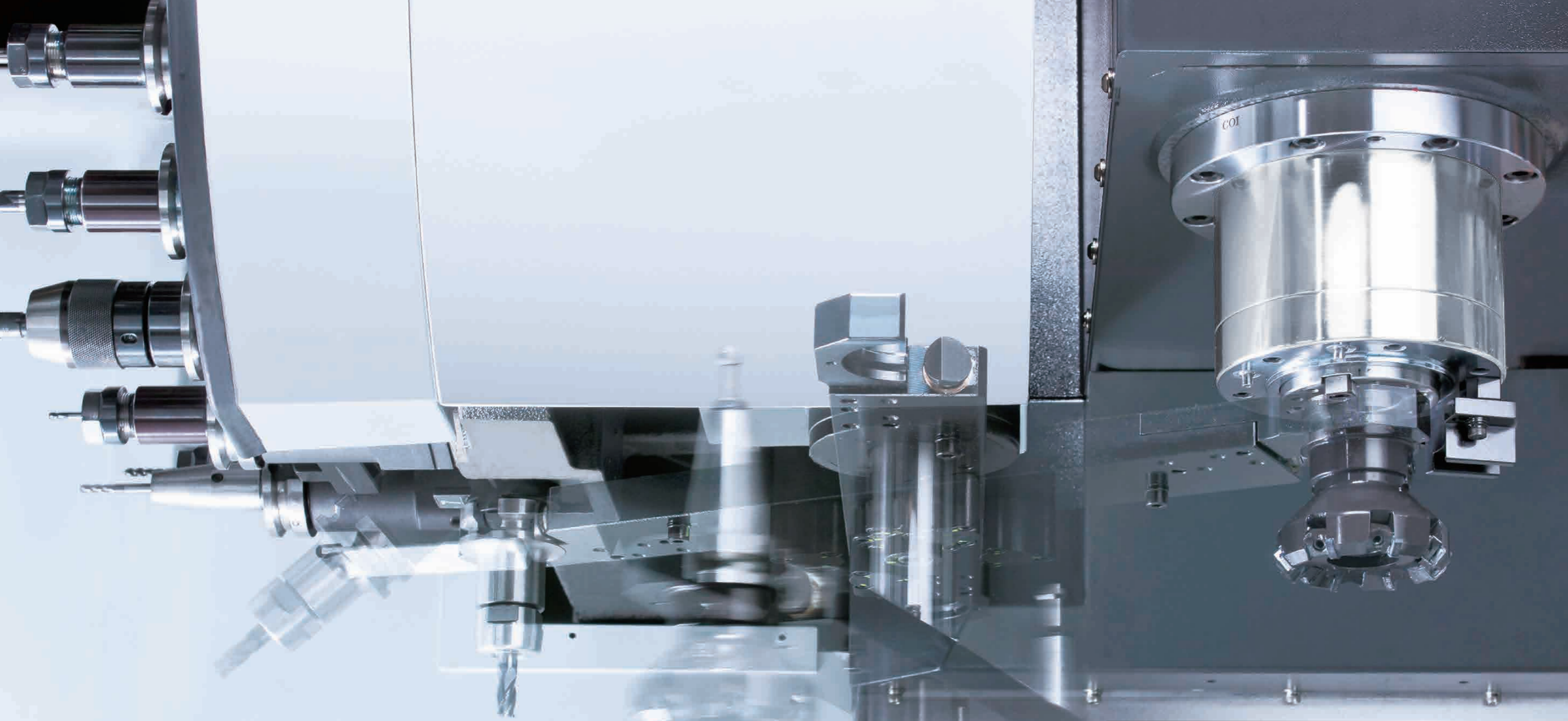

24T Disc type tool magazine



## Chip Disposal System

- All series are equipped with chip auger. Single or triple chip augers are adopted according to different models.
- The optional high pressure chips flush coolant system is also available.

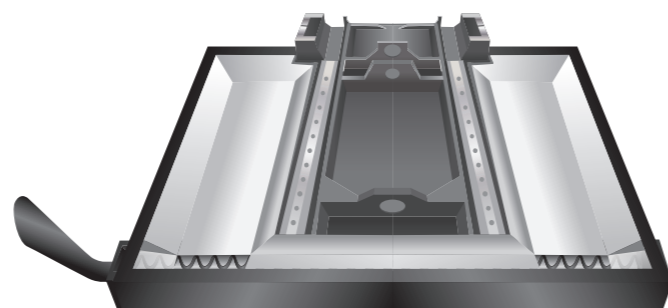

■ Single chip auger x 1

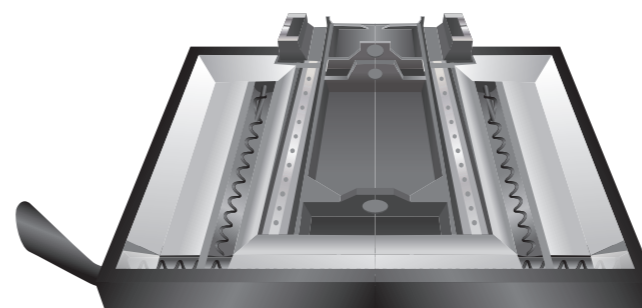

■ Single chip augers x 3

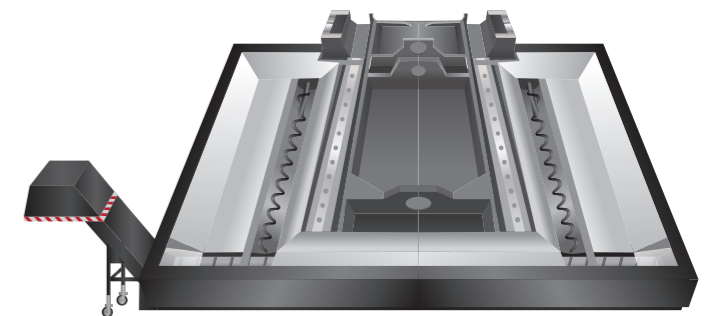

■ Chain Type Chip Conveyor ( Opt. )

# Optional Compound Guide Ways

*Fulfilling Your High Speed And Heavy Cutting Needs*

- Z-axis could adopt with heat treated box way structure with gear box spindle. Very suitable for heavy cutting requirements.
- Three axes compound structure design provide both benefits of heavy cutting capacity on Z-axis box way plus fast moving high accuracy features of linear guide ways on X and Y axes.

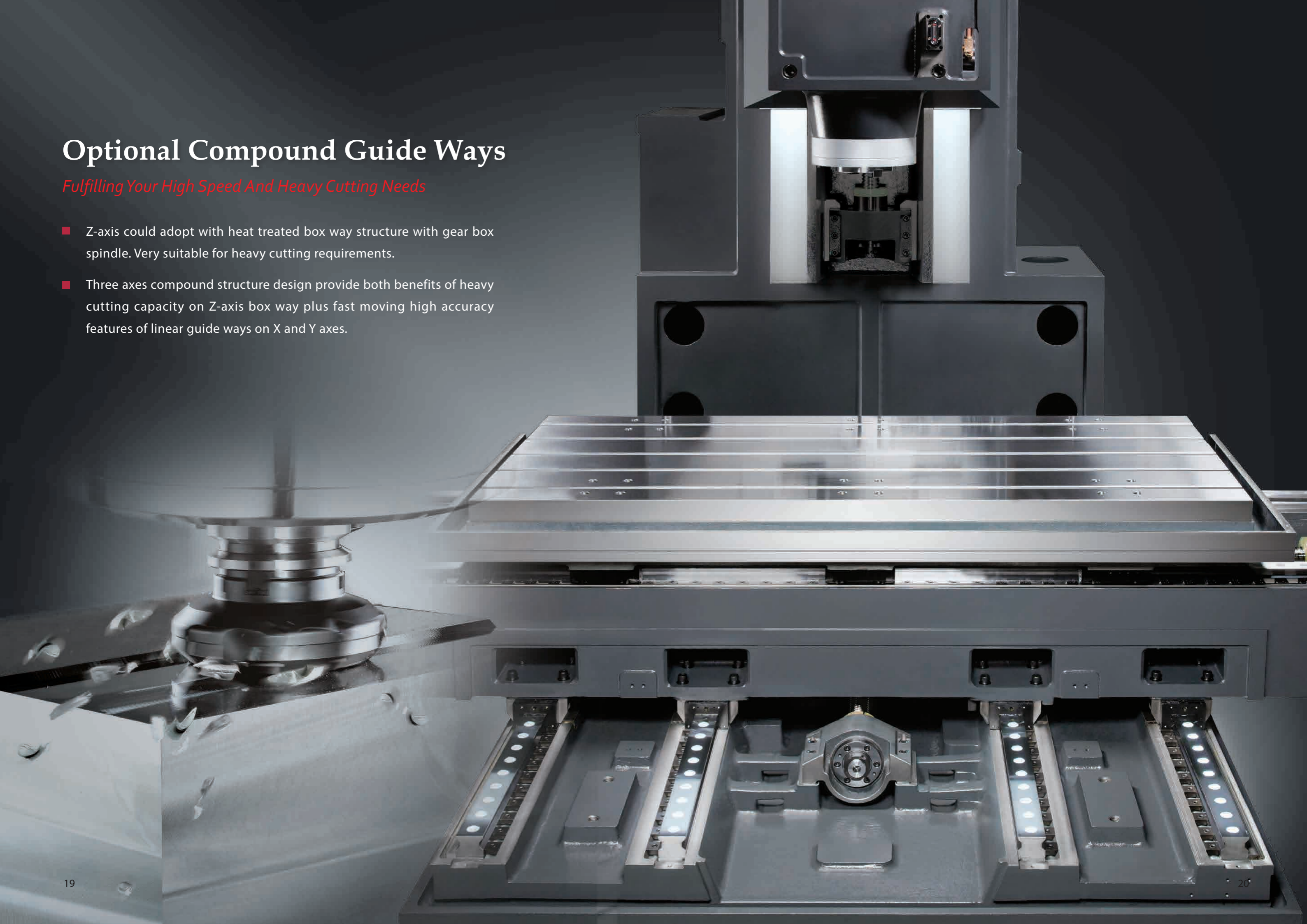

# Optional APC System

*Fulfilling Your Mass Production Needs*

The high-quality, world famous Japanese auto parts machining plants, is recently installed with AWEA AF-860APC for processing of automotive intake manifold, gear box shell and other key components. Because of the AWEA machine high quality and high reliability performance, the installation quantity is continued to grow up.

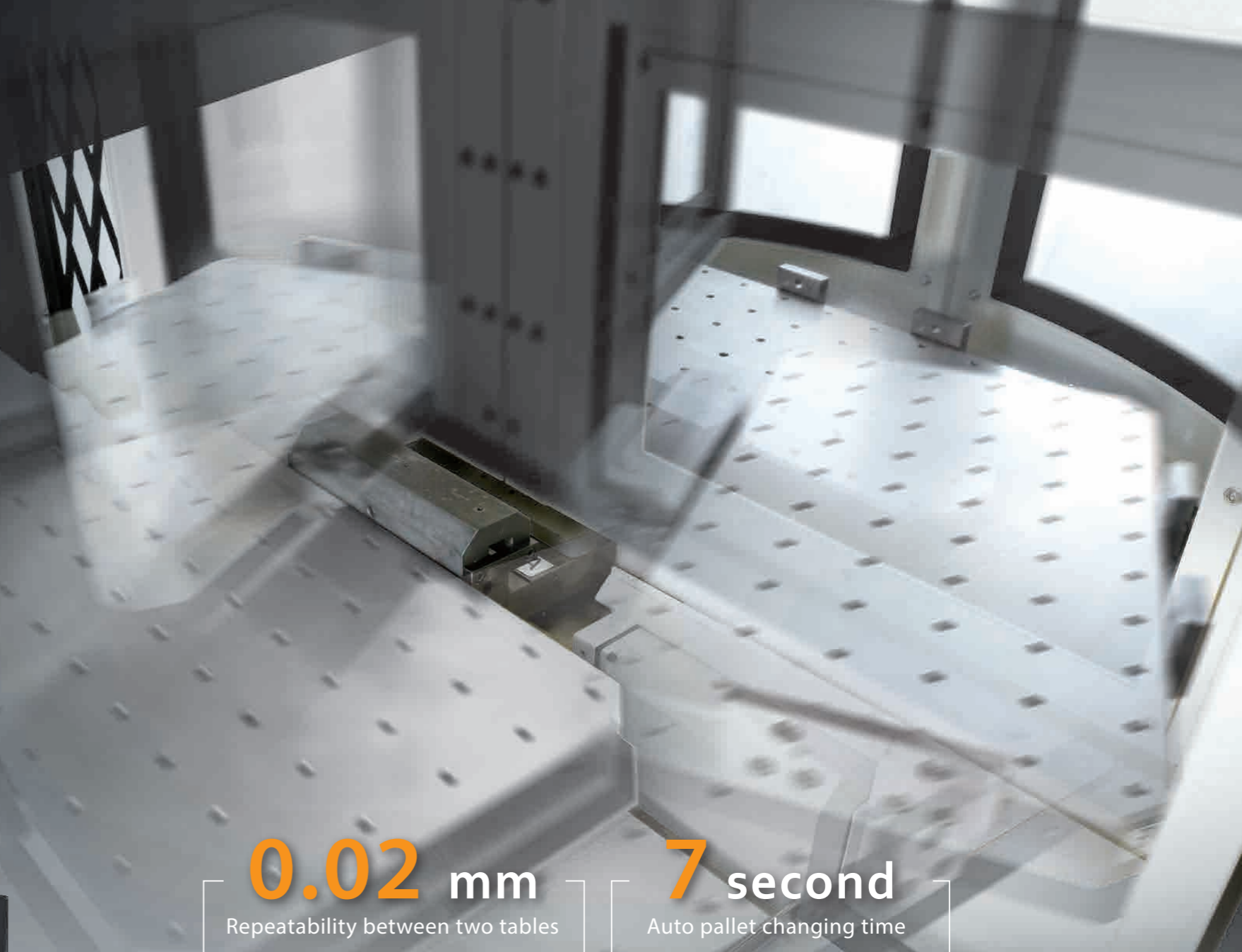

**0.02 mm**  
Repeatability between two tables

**7 second**  
Auto pallet changing time

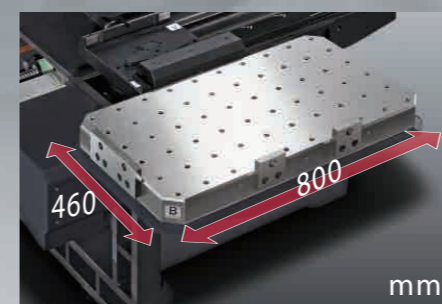

Table size

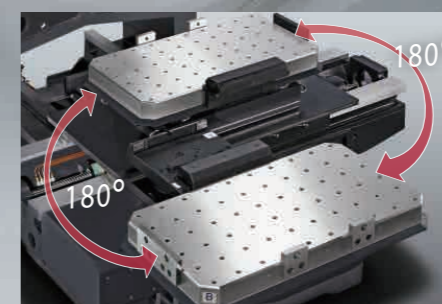

Table rotating range

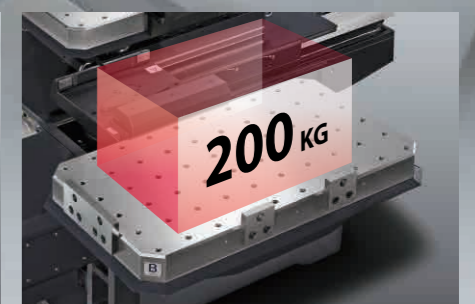

Table load capacity

Model	AF860-APC	Model	AF860-APC
X / Y / Z axes travel	860 / 600 / 600 mm	Spindle taper	BT40
Table size	460 x 800 mm	Spindle motor ( cont. / 30 min. )	7.5 / 11 kW
Table rotating range	180°	Spindle speed	8,000 rpm
Repeatability for each table	0.01 mm	X / Y / Z axes rapid feed rate	48 / 48 / 32 m/min.
Repeatability between two tables	0.02 mm	Cutting feed rate	10 m/min.
Table load capacity	200 kg x 2	Tool magazine capacity	24 T

# Dimensions

(Unit: mm)

## Table Dimensions

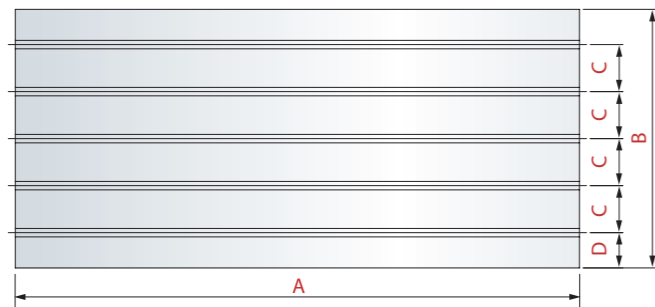

## T-slot Dimensions

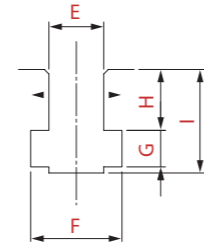

Models	A	B	C	D	E	G	H	I	J	No.*1
AF-610	700	450	100	75	14	24	10	15.5	26.5	4
AF-650	750	510	100	105	14	24	10	15	25.5	4
AF-760	860	510	100	105	14	24	10	15	25.5	4
AF-860	1,000	600	100	100	18	30	12	24	37.5	5
AF-1000	1,200	550	100	75	18	30	12	20	34	5
AF-1060	1,200	600	100	100	18	30	12	24	37.5	5
AF-1250	1,350	620	100	110	18	30	12	24	37.5	5
AF-1460	1,500	620	100	110	18	30	12	24	37.5	5
AF-1400	1,500	800	150	100	18	30	13	20	34	5
AF-1600	1,700	800	150	100	18	30	13	20	34	5
AF-1800	1,900	800	150	100	18	30	13	20	34	5

\*1 : No. = Number of T-slots

## Tool Shank and Pull Stud Dimensions

### BT40

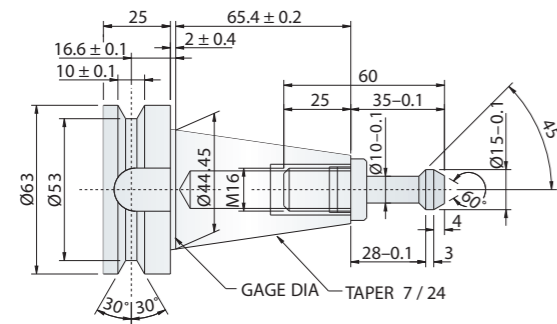

### BT50

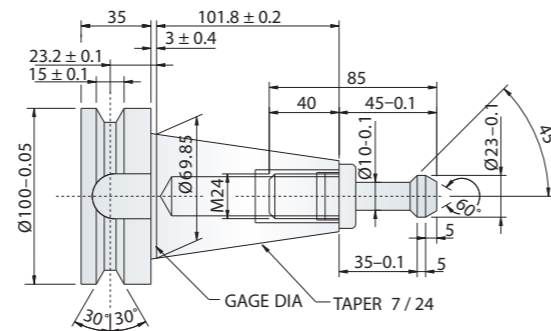

### DIN40

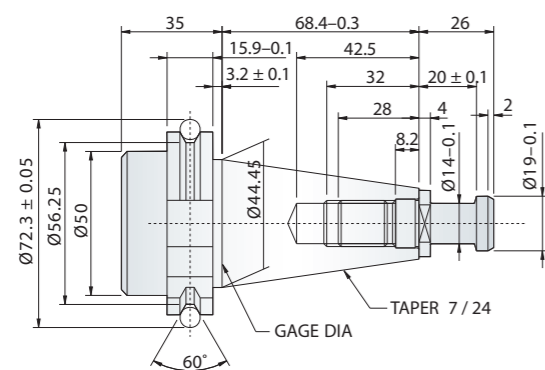

### DIN50

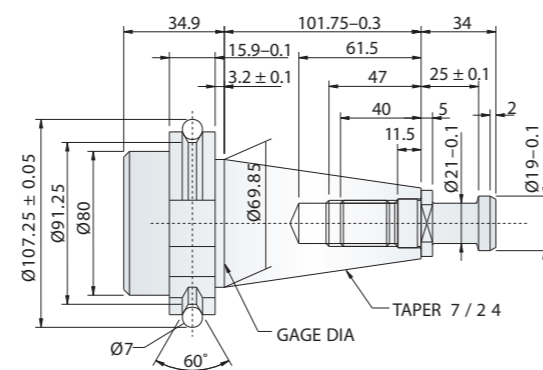

## Machine Dimensions

AF-1000	BT40 - 32 / 40T : 865 mm
AF-860 / 1060	BT40 - 40T : 745 mm
AF-1250 / 1460	BT40 - 40T : 720 mm BT40 - 60T : 1,405 mm
AF-1400 ~ 1800	BT50 - 30T : 985 mm

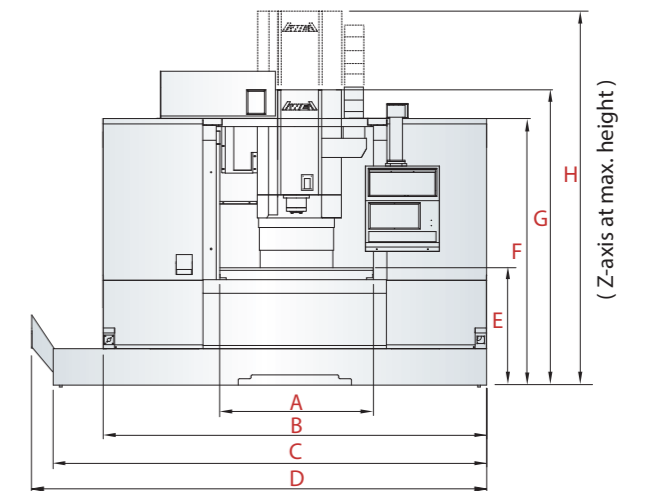
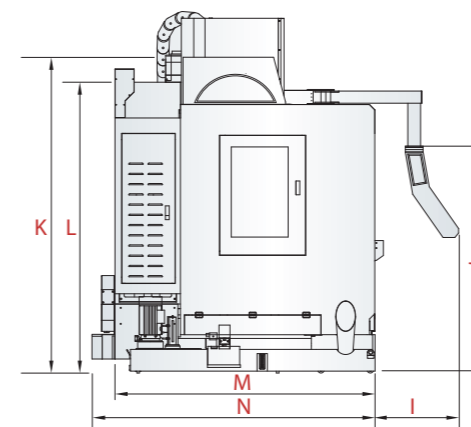
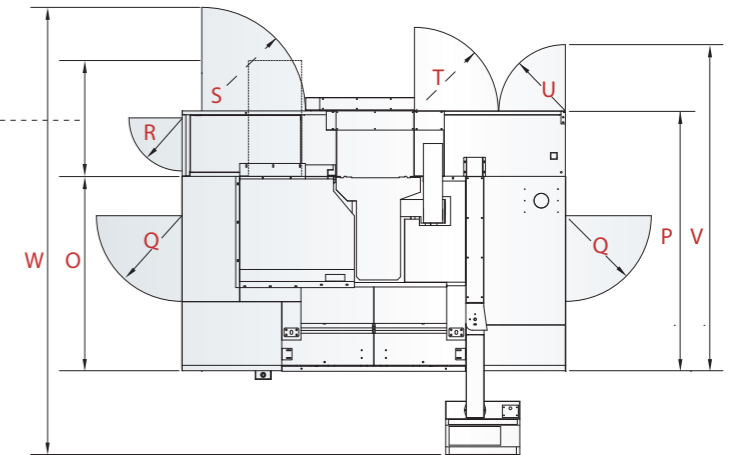

(Unit: mm)

Models	A	B	C	D	E	F	G	H	I	J	K	L
AF-610	900	2,090	2,090	2,420	800	1,900	--	--	400	1,210	2,300	1,950
AF-650	875	2,200	2,415	2,703	825	1,905	2,305	2,815	615	860	2,285	1,905
AF-760	875	2,200	2,415	2,703	825	1,905	2,305	2,815	615	860	2,285	1,905
AF-860	1,100	2,600	2,810	3,205	950	2,050	2,435	3,035	655	1,830	2,610	2,260
AF-1000	1,200	3,000	3,390	3,643	915	2,080	1,905	2,540	655	1,765	2,520	2,170
AF-1060	1,300	3,100	3,310	3,710	950	2,050	2,435	3,035	655	1,830	2,610	2,260
AF-1250	1,250	3,400	3,400	3,920	880	2,025	2,380	3,000	655	1,830	2,695	2,300
AF-1460	1,500	3,850	3,850	4,375	880	2,025	2,380	3,000	655	1,830	2,695	2,300
AF-1400	1,550	3,950	3,950	4,278	1,050	2,315	2,645	3,445	655	1,840	3,330	2,980
AF-1600	1,750	4,400	4,400	4,728	1,050	2,315	2,645	3,445	655	1,840	3,330	2,980
AF-1800	1,900	4,880	4,880	5,208	1,050	2,315	2,645	3,445	655	1,840	3,330	2,980

Models	M	N	O	P	Q	R	S	T	U	V	W
AF-610	2,500	2,500	1,358	2,310	650	400	--	545	--	3,255	--
AF-650	2,100	2,595	1,440	2,595	670	400	--	545	545	3,840	--
AF-760	2,100	2,595	1,440	2,595	670	400	--	545	545	3,840	--
AF-860	2,195	2,375	1,650	2,150	670	400	840	335	580	3,140	3,645
AF-1000	2,040	2,220	1,520	2,030	670	400	810	335	560	3,345	3,495
AF-1060	2,195	2,375	1,650	2,150	670	400	1,100	335	580	3,140	3,495
AF-1250	2,200	2,380	1,650	2,200	800	400	895	550	580	3,405	3,750
AF-1460	2,200	2,380	1,650	2,200	800	400	895	550	580	3,405	3,750
AF-1400	2,915	3,095	2,175	2,875	900	--	--	600	620	4,130	--
AF-1600	2,915	3,095	2,175	2,875	900	--	--	600	620	4,130	--
AF-1800	2,915	3,095	2,175	2,875	900	--	--	600	620	4,130	--

Specifications are subject to change without notice.

		AF-610	AF-650	AF-760	AF-860	AF-1000	AF-1060
<b>SPECIFICATIONS</b>							
X-axis travel	mm	610	650	760	860	1,020	1,060
Y-axis travel	mm	450	510	510	600	550	600
Z-axis travel	mm	450	510	510	600	635	600
Distance from spindle center to column	mm	510	552	552	740	588	740
Distance from spindle nose to table top	mm	150 ~ 600	100 ~ 610	100 ~ 610	100 ~ 700	100 ~ 735	100 ~ 700
<b>TABLE</b>							
Table size ( X direction )	mm	700	750	860	1,000	1,200	1,200
Table size ( Y direction )	mm	450	510	510	600	550	600
Table load capacity	kg	450	500	500	700	700	700
T slot ( Width x Pitch x No. )		14 mm x 100 mm x 4			18 mm x 100 mm x 5		
<b>SPINDLE</b>							
Spindle taper		BT40		BT40 ( BT50 Opt. )			
Spindle motor ( cont. / 30 min. )	kW	7.5 / 11					
Max. spindle speed	rpm	Belt-drive 8,000 / 10,000					
<b>FEED RATE</b>							
X / Y axes rapid feed rate	m/min.	32	48	48	48	36	48
Z-axis rapids feed rate	m/min.	24	32	32	32	24	32
Cutting feed rate	m/min.	15					
<b>TOOL MAGAZINE</b>							
Tool magazine capacity	T	24					
Max. tool length	mm	250					
Max. tool weight	kg	7					
Max. tool diameter / adj. pocket empty	mm	Ø 75 / Ø 150					
<b>ACCURACY</b>							
Positioning accuracy ( ISO230-2 )	mm	0.006					0.008
Repeatability ( ISO230-2 )	mm	0.005					0.006
<b>GENERAL</b>							
Control system		FANUC Oi - MF					
Pneumatic pressure requirement	kg/cm <sup>2</sup>	6					
Power requirement	kVA	20	25	25	30	30	30
Coolant tank capacity	liter	160	270	270	320	360	340
Machine weight	kg	3,500	4,200	5,000	5,800	7,000	7,000

### Standard Accessories

- Spindle air curtain
- Coolant nozzle around spindle
- Spindle cooling system
- Centralized automatic lubricating ( X / Y / Z )
- Fully enclosed splash guard
- Coolant equipment
- Chip augers
- Automatic power-off system
- Heat exchanger for electrical cabinet
- Foundation bolt kit

- Tool box
- Air gun
- Alarm light

		AF-1250	AF-1460	AF-1400	AF-1600	AF-1800
<b>SPECIFICATIONS</b>						
X-axis travel	mm	1,250	1,400	1,400	1,600	1,800
Y-axis travel	mm	620	620	800	800	800
Z-axis travel	mm	620	620	800	800	800
Distance from spindle center to column	mm	730		903		903
Distance from spindle nose to table top	mm	100 ~ 720		200 ~ 1,000		200 ~ 1,000
<b>TABLE</b>						
Table size ( X direction )	mm	1,350	1,500	1,500	1,700	1,900
Table size ( Y direction )	mm	620	620	800	800	800
Table load capacity	kg	1,000	1,000	1,200	1,500	1,800
T slot ( Width x Pitch x No. )		18 mm x 100 mm x 5		18 mm x 150 mm x 5		
<b>SPINDLE</b>						
Spindle taper		BT40 ( BT50 Opt. )				
Spindle motor ( cont. / 30 min. )	kW	7.5 / 11		11 / 15		
Max. spindle speed	rpm	Belt-drive 8,000 / 10,000		Direct-drive 10,000		
<b>FEED RATE</b>						
X / Y axes rapid feed rate	m/min.	48	48	30	30	30
Z-axis rapids feed rate	m/min.	36	36	24	24	24
Cutting feed rate	m/min.	15		12		
<b>TOOL MAGAZINE</b>						
Tool magazine capacity	T	24				
Max. tool length	mm	250		300		
Max. tool weight	kg	7		15		
Max. tool diameter / adj. pocket empty	mm	Ø 75 / Ø 150		Ø 105 / Ø 210		
<b>ACCURACY</b>						
Positioning accuracy ( ISO230-2 )	mm	0.008				
Repeatability ( ISO230-2 )	mm	0.006				
<b>GENERAL</b>						
Control system		FANUC Oi - MF				
Pneumatic pressure requirement	kg/cm <sup>2</sup>	6				
Power requirement	kVA	35	35	40		
Coolant tank capacity	liter	430	470	610	630	660
Machine weight	kg	8,000	8,200	14,000	16,000	18,000

Specifications are subject to change without notice.

### Optional Accessories

- 30 / 32 / 40 / 60 tool magazine
- Belt-drive spindle
  - BT40 8,000 / 10,000 rpm
  - BT50 6,000 rpm
- Direct-drive spindle
  - BT40 10,000 / 12,000 / 15,000 rpm
  - BT50 8,000 / 10,000 rpm
- Coolant through spindle ( CTS )
- Spindle thermal compensation
- Oil skimmer
- CNC rotary table
- A / C cooler for electrical cabinet
- Coolant through the tool adapter
- Chip wash down coolant system
- Automatic tool length measurement
- Automatic work piece measurement
- Gravity axis anti-drop function
- MITSUBISHI / HEIDENHAIN control system
- Chip conveyor and bucket
- Optical Linear scale
- Transformer